

### Optie 1: uitbouw 1,2m achtergevel

Optie is toepasbaar voor alle bouwnummers

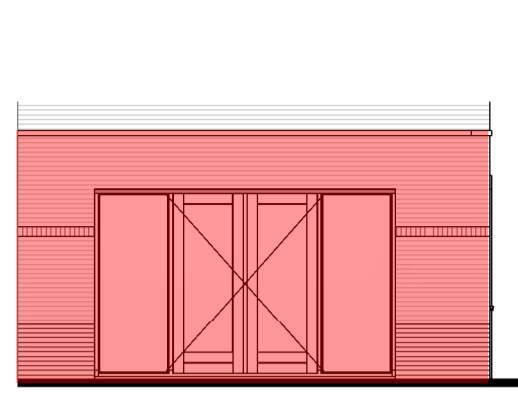

Achtergevel

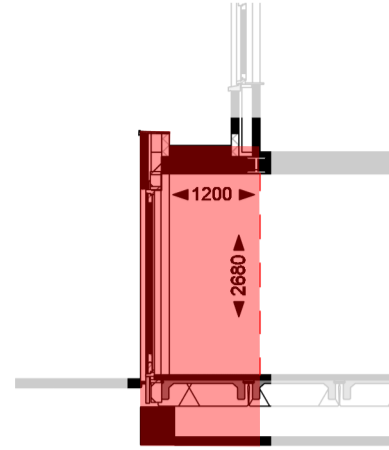

Doorsnede

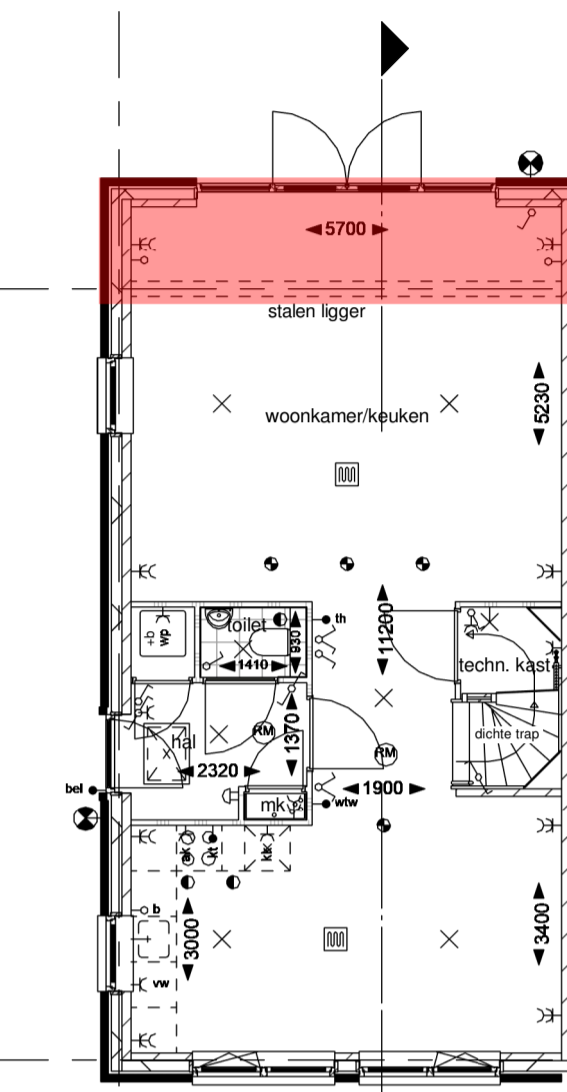

Begane grond



Zijgevel

### Optie 2: uitbouw 2,4m achtergevel

Optie is toepasbaar voor alle bouwnummers

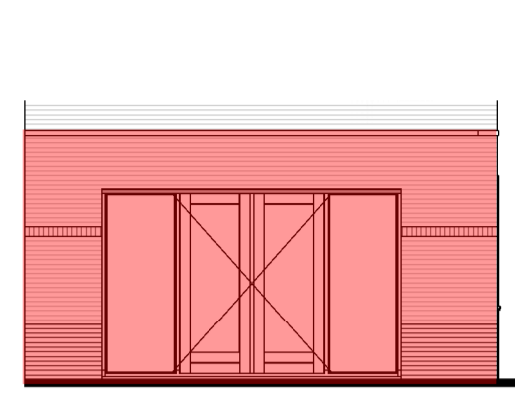

Achtergevel

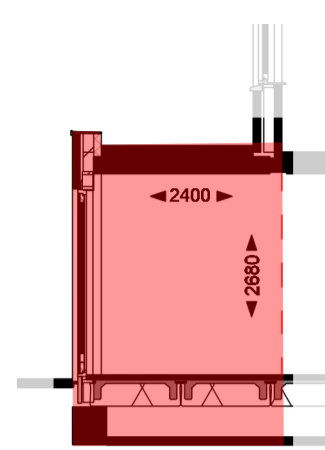

Doorsnede

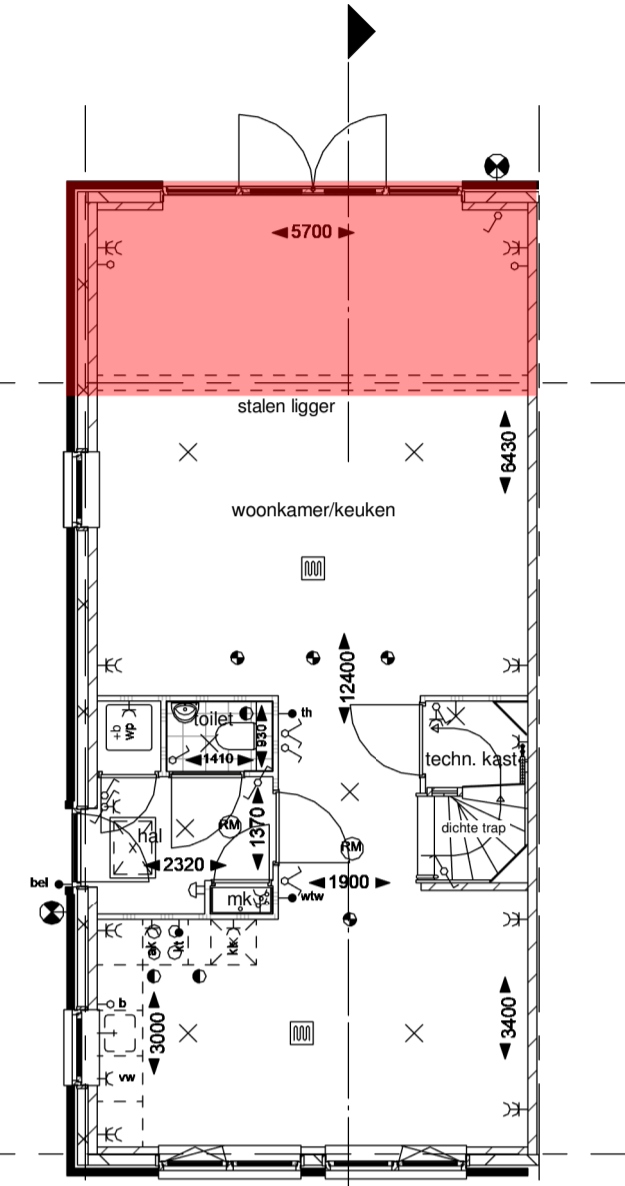

Begane grond

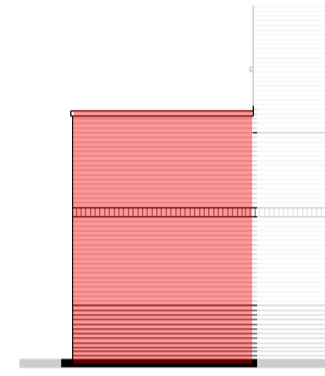

Zijgevel

### Optie 3: dakraam achterzijde

Optie is toepasbaar voor alle bouwnummers

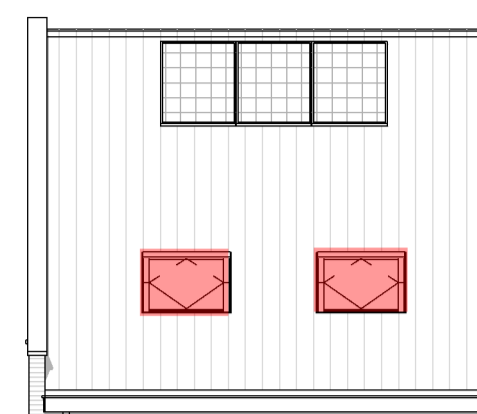

Voorzijde

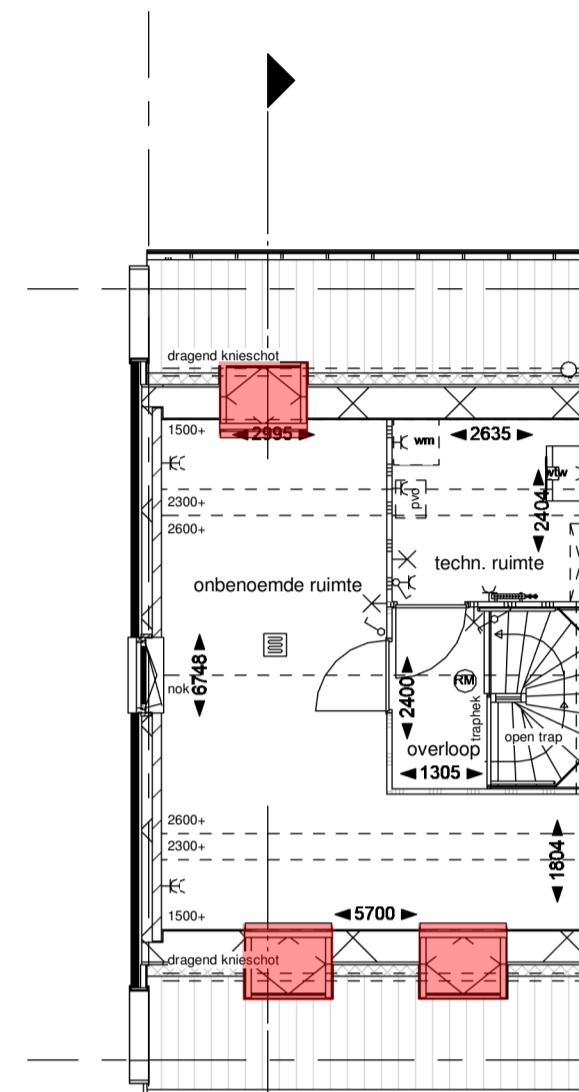

Tweede verdieping

### Optie 3A: dakraam voorzijde

Optie is toepasbaar voor bouwnummers 72 en 75

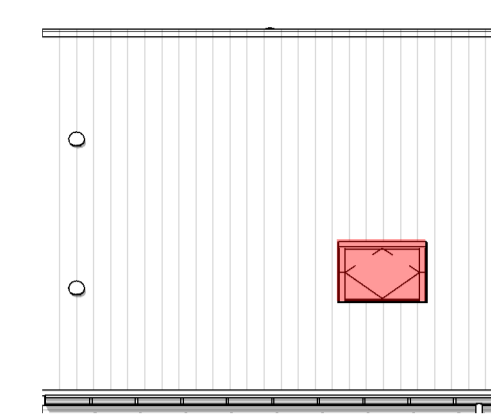

Achterzijde

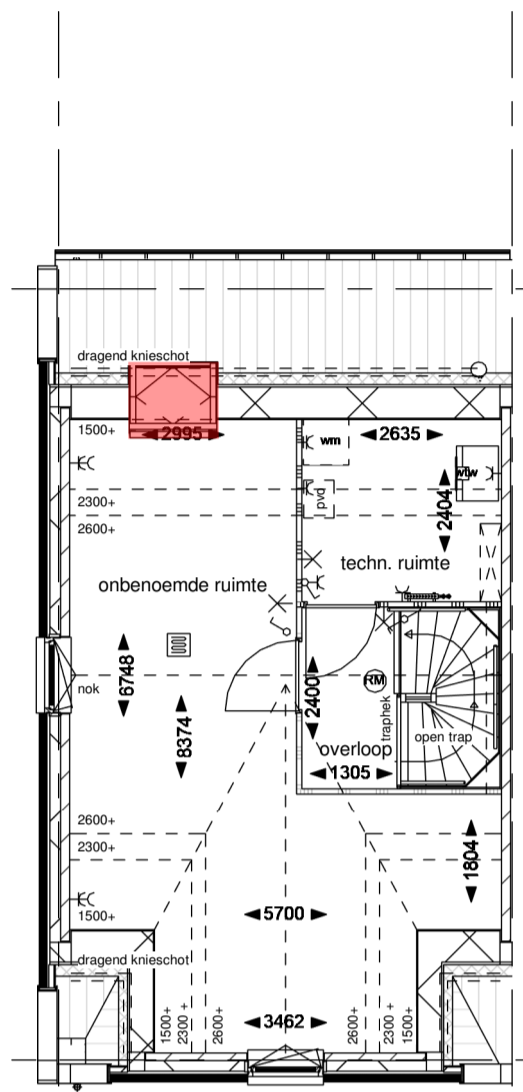

Tweede verdieping

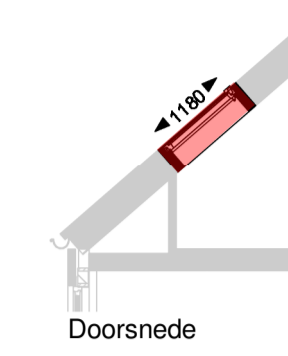

Doorsnede

### Optie 4: dakkapel achterzijde

Optie is toepasbaar voor alle bouwnummers

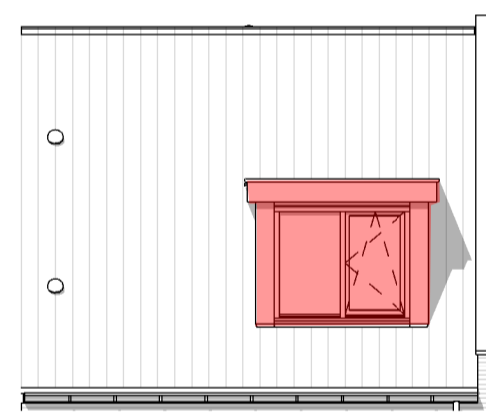

Achterzijde

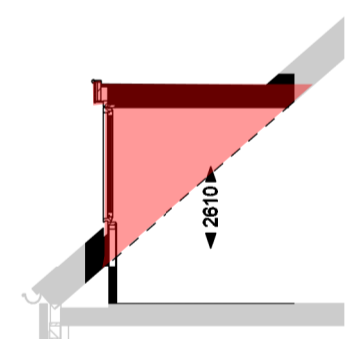

Doorsnede

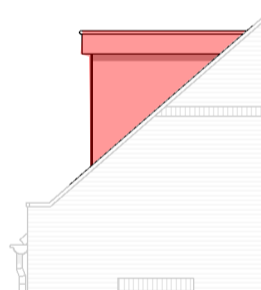

Zijgevel

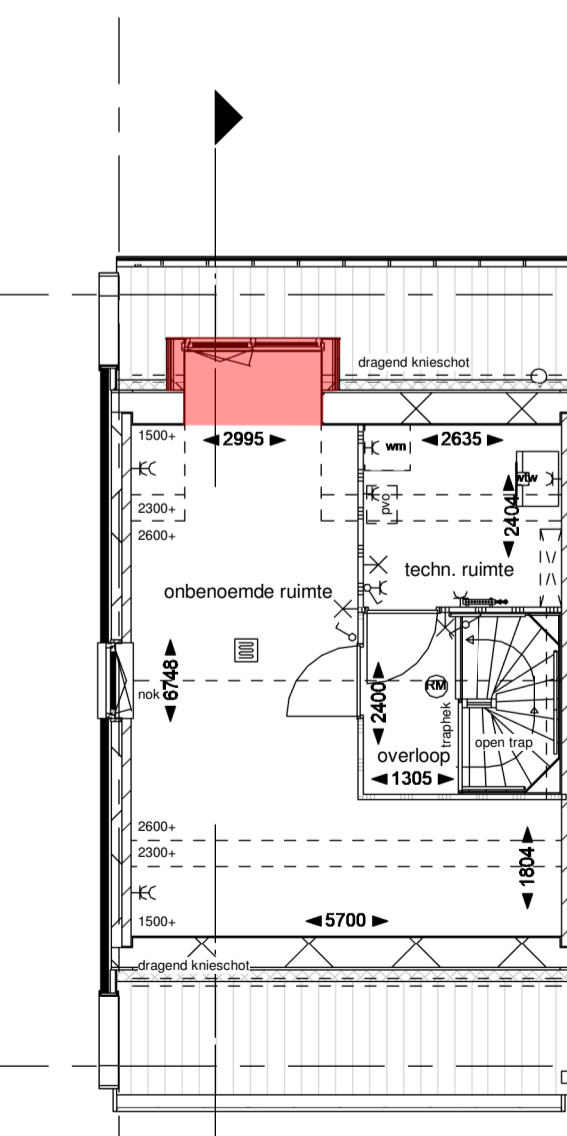

Tweede verdieping

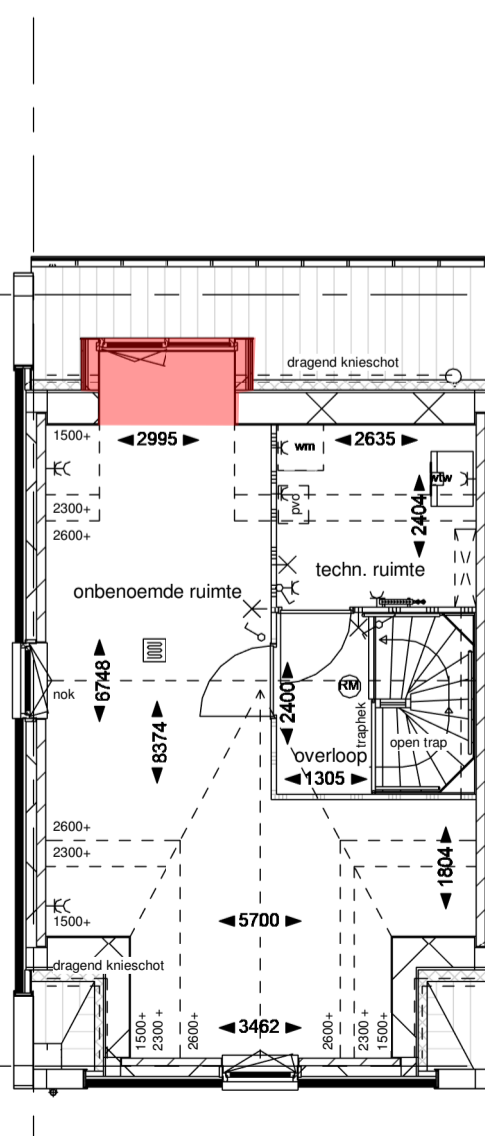

Tweede verdieping

**RODENRIJSE  
VELDEN**  
Wonen aan de groene rand van Rotterdam

Project: Rodenrijse Velden te Berkel en Rodenrijs

Bladomschrijving: Opties blok 24 en 25 / bnr. 72 t/m 75

Bladnummer: VT-O-08

Schaal: 1:100

Datum: 13-03-2020 Wijziging A: B: